

## Model PRH09i

### Stainless-Steel In-Line Pressure Regulator (Reducing Valve)

149.95 0 0 47.24 28.35 766.30 cm /11 Do Q



- Spring and double piston operated

- 1/2"-3" NPT THD Stainless Steel Model ( For Hastelloy, Alloy 20, Monel, and Titanium model **contact factory**)
- Inlet pressures to 600 PSI (41 Bar)
- Outlet pressures from 20 psig (1.4 barg) to 450 PSI (30 Bar) multiple spring ranges
- Max operating temperatures -40 to 300 °F (-40 to 150 °C) depending on elastomers selected

## Features

- **Pressure-containing parts** made from solid bar stock materials — unlike castings which have wall thickness variations.
- **Body and trim:** Standard material is type 303 or 316 stainless steel. Special alloys (e.g. Hastelloy, Monel, Titanium, and Alloy 20) also available, [click here](#).
- **Elastomeric piston seals:** Viton is standard. Alternates when specified are Buna, EPDM, and Kalrez.
- **Spring chamber and adjusting spring:** These parts are non-wetted, are not in contact with the fluid or gas, and are normally offered in carbon steel, painted for minimal exterior corrosion-resistant protection. When these parts are submerged or located in a corrosive atmosphere, they can be upgraded to a stainless steel or other corrosion-resistant materials at an additional cost.
- **Standard porting:** In-line porting, NPT threads. Valve works in any orientation, upright as illustrated, horizontal, etc.
- **Other options:** See below

## Applications

Designed for clean, filtered or strained, non-abrasive liquid service: oils, lubricants, greases, solvents, and most chemicals compatible with seals selected. Valve is piston-operated, seat option and seals as selected. **Do not use metal seat for extended shutoff service** or for extremely low flows (less than 5% of maximum capacity). Values below the low limit of the spring ranges shown below can be achieved if the flow rates are substantially higher than the minimum 5% of maximum rated capacity. To be on the safe side, a relief or bypass valve should always be installed on the outlet side of the regulator (not included with valve). For outlet pressures above the ranges stated below, request the single piston model **PRH04**, that is specifically designed to handle the higher outlet pressures that the PRH09 cannot handle. Do not use with liquids that tend to crystallize or solidify under operating conditions. Generally not for use on high pressure steam service as operating temperatures can easily exceed the limitations of the seal selections below. Consult factory for steam & gas service. Although the metal seat is standard, for gas service a soft seat such as Viton, Buna or EPDM may be offered for improved shut off capability compared to a metal seat. Consult factory.

The balanced piston design of this model accommodates large variations in inlet pressure. When ordered, if a set pressure is not specified, valves are set to the minimum pressure setting for the range selected. Valve can operate in any orientation: vertical, horizontal, etc. A high-pressure filter or strainer, which should be no coarser than #20 mesh, can be ordered from Straval. See model **SBS-10**.

**We now offer some models that meet NACE MR0175. These are not priced on line. Consult factory.**

## Options

- Reduced trim for low-flow applications, all sizes.
- Locking cap to enclose adjusting screw (1).
- Wetted materials (7,10, 15, 16) in type 316SS, Monel, titanium, and Hastelloy.
- Upgrade non-wetted spring chamber (5), spring hardware (2,5), and adjusting screw (1) to 300 series stainless steel.
- Hard-chromed piston (7) for longer life and seal (9) wear.

## Principle of Operation

This valve operates with a compression spring acting on the main valve which is used to adjust the outlet pressure with an adjusting screw. The reduced outlet pressure is very easily adjusted in the field. To increase outlet pressure, simply loosen adjusting screw lock nut (2) to increase spring compression by turning the adjusting screw (1) inward. Similarly, to get a lowering in outlet pressure requires a reduction in spring compression by turning the screw outward. A pressure gauge is required on the outlet side of the regulator somewhere in the downstream piping about 10 pipe diameters after the valve, to monitor the result while making the adjustment. The valve will operate in a vertical orientation as illustrated, horizontal, or any other orientation.

---

## Typical Illustration PRH09i

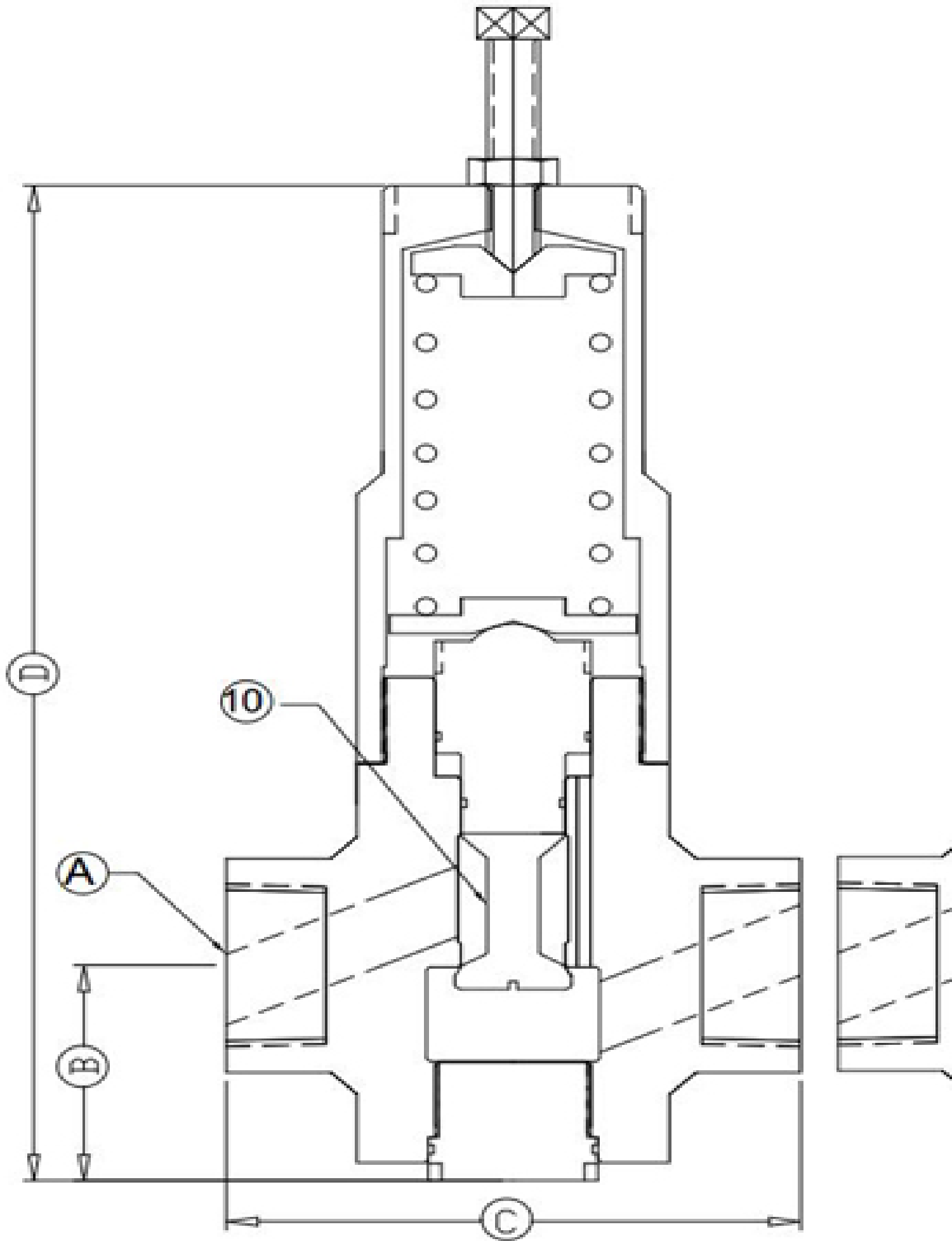

## Material List and Specification

PRH09i-THD SERIES BOM		
#	Description	Available Material
1	Screw	CS, 303SS, 316SS
2	Nut	CS, 304SS, 316SS
3	Pusher	CS, 304SS, 316SS
4	Spring	CRSi, 302SS, 316SS
5	Spring Chamber/Housing	CS, 303SS, 316SS
6	Follower	CS, 303SS, 316SS
7	Piston	303SS, 316SS
8	Piston Seal (Large)	Viton, Buna, EPDM, Kalrez
9	Piston Seal (Small)	Viton, Buna, EPDM, Kalrez
10	Popper (Soft or Metal Seat)	303SS, 316SS
11	Seat Seal	Viton, Buna, EPDM, Kalrez
12	Seat Retainer (Soft Seat Only)	303SS, 316SS
13	Seat Retaining Bolt (Soft Seat Only)	304SS, 316SS
14	Plug	303SS, 316SS
15	Plug Seal	Viton, Buna, EPDM, Kalrez
16	Body	303SS, 316SS

## Dimensions (inches)

Reference Dimension Chart			
"A"	"B"	"C"	"D"
1/2	2 1/8	3 1/2	10 1/2
3/4	2 1/8	3 1/2	11
1	2 1/4	3 1/2	11 1/2
1 1/4	2 1/4	5 1/2	12
1 1/2	2 1/4	5 1/2	12
2	3 1/2	6 1/4	13 1/4
2 1/2	3 1/2	6 1/4	13 1/4
3	3 1/2	10 1/4	17 1/2

Note: Dimensions are approximate and are subject to change without notice. Request certified dimensions before final product installation.

## 1/2" PRH09i-05T

Max Inlet pressure 600 psig (41.36 barg)

Multiple Spring Ranges from:10-450 psig (0.69-31 barg) Select spring from pricing page

---

## **3/4" PRH09i-07T**

**Max Inlet pressure 600 psig (41.36 barg)**

Multiple Spring Ranges from:10-450 psig (0.69-31 barg) Select spring from pricing page

---

## **1" PRH09i-10T**

**Max Inlet pressure 600 psig (41.36 barg)**

Multiple Spring Ranges from:15-450 psig (1.03-31 barg) Select spring from pricing page

---

## **1-1/4" PRH09i-12T**

**Max Inlet pressure 600 psig (41.36 barg)**

Multiple Spring Ranges from:15-450 psig (1.03-31 barg) Select spring from pricing page

---

## **1-1/2" PRH09i-15T**

**Max Inlet pressure 600 psig (41.36 barg)**

Multiple Spring Ranges from:15-450 psig (1.03-31 barg) Select spring from pricing page

---

## **2" PRH09i-20T**

**Max Inlet pressure 600 psig (41.36 barg)**

Multiple Spring Ranges from:15-235 psig (1.03-16.2 barg) Select spring from pricing page

---

## **2-1/2" PRH09i-25T**

**Max Inlet pressure 600 psig (41.36 barg)**

Multiple Spring Ranges from:15-235 psig (1.03-16.2 barg) Select spring from pricing page

---

## **3" PRH09i-30T**

**Max Inlet pressure 600 psig (41.36 barg)**

Multiple Spring Ranges from:25-235 psig (1.72-16.2 barg) Select spring from pricing page

---

The spring ranges listed above are not achievable with one spring, but are compressed to show overall product capability. Select a specific spring range in the pricing pages or specify a set pressure when ordering.