



Phone (toll-free): (888) 380-9660  
Phone (local): (973) 340-9955  
Fax: (973) 340-9933  
Web: www.straval.com

21 Columbus Avenue  
Garfield, NJ 07026

## Model SBV-05

### BASKET STRAINER - SIMPLEX

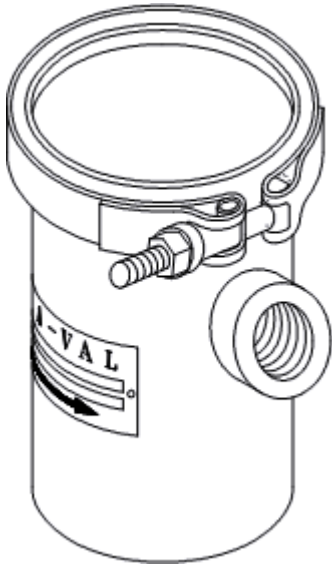

- 316 stainless steel
- 1/2"-2" NPT THD
- Stainless steel perf or mesh
- Pressures to 150 PSI (10 Bar); temp to 250 °F (121 °C)

### Features

- **Body:** Made from heavy-gauge 316 stainless steel for corrosive service or carbon steel for non-corrosive service.
- **V-band clamp** for quick and easy removal and cleaning of basket. Stainless steel.
- **Heavy-duty basket** constructed of stainless steel perf and additional wire mesh as required.
- **Perf:** Available from .020" to 3/16" openings (stainless steel only).
- **Mesh:** As small as .0025" openings. 60 micron (#250 mesh) stainless steel only.
- **Gasket:** Available in Viton, Buna, EPDM, and Teflon.
- **Parallel ports:** NPT connections are standard. Special connections including flanges are also available.

### Applications

This heavy-duty strainer can be used for liquids, low-pressure steam, and gases for operating pressures up to 150 PSI (10 Bar) and temperatures up to 250 °F (121 °C). It is used to protect various pipeline components such as pressure-reducing valves, relief valves, etc. that require clean, filtered, or strained liquids to keep these devices operational. The strainer basket element is constructed of a heavy-duty stainless perf element with opening sizes from .020" up to 3/16", and when required, an additional stainless steel wire mesh can be added to screen out fine particles down to .0025". Note that overall body length can be adjusted to meet individual net flow basket area requirements.

Although not illustrated, the strainer body can also be made available with 150# flanges.

The strainer is equipped with a V-band clamp for simple and quick removal and cleaning of the strainer basket when it becomes clogged. Where much higher operating pressures are expected, refer to our high pressure model SBS-10.

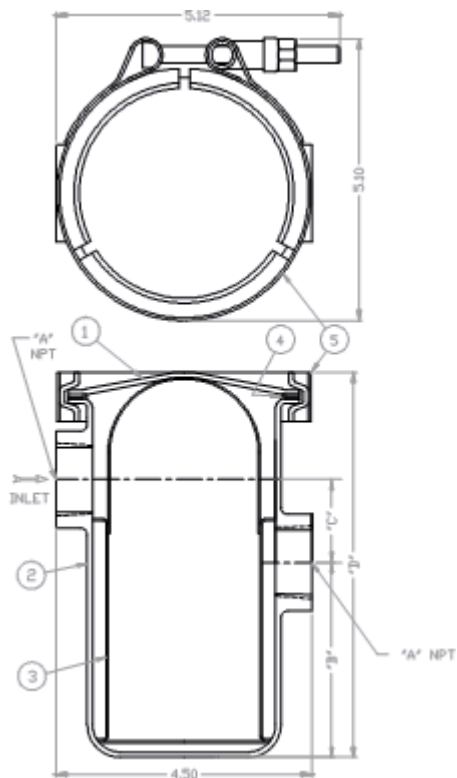

## SBV-05

### Material List and Specification

- |    |          |                 |
|----|----------|-----------------|
| 1. | Cover    | Stainless steel |
| 2. | Body     | Stainless steel |
| 3. | Basket   | Stainless steel |
| 4. | * Gasket | Viton           |
| 5. | V-clamp  | Stainless steel |

\*Gasket also available in EPDM, Buna, and Teflon

### Dimensions

A	B	C	D
1/2	2.88	1.19	6
3/4	2.81	1.25	6
1	2.56	1.75	6.5
1-1/4	3.38	2.19	7.5
1-1/2	3.94	2.38	8.5

Note: Dimensions are approximate and are subject to change without notice. Request certified dimensions before final product installation.

---

## 1/2" SBV05-05T

**Strainers with Perf Baskets: Body 150# psi Rating (10 bar)**

Particle sizes from:0.062-0.125 in (1.575-3.175 mm)

---

**Strainers with Mesh Baskets: Body 150# psi Rating (10 bar)**

Particle sizes from:0.0024-0.045 in (0.061-1.143 mm)

---

## 3/4" SBV05-07T

**Strainers with Perf Baskets: Body 150# psi Rating (10 bar)**

Particle sizes from:0.062-0.125 in (1.575-3.175 mm)

---

**Strainers with Mesh Baskets: Body 150# psi Rating (10 bar)**

Particle sizes from:0.0024-0.045 in (0.061-1.143 mm)

---

## 1"SBV05-10T

**Strainers with Perf Baskets: Body 150# psi Rating (10 bar)**

Particle sizes from:0.062-0.125 in (1.575-3.175 mm)

---

**Strainers with Mesh Baskets: Body 150# psi Rating (10 bar)**

Particle sizes from:0.0024-0.045 in (0.061-1.143 mm)

---

## 1 1/4" SBV05-12T

**Strainers with Perf Baskets: Body 150# psi Rating (10 bar)**

Particle sizes from:0.062-0.125 in (1.575-3.175 mm)

---

**Strainers with Mesh Baskets: Body 150# psi Rating (10 bar)**

Particle sizes from:0.0024-0.045 in (0.061-1.143 mm)

---

## 1 1/2" SBV05-15T

**Strainers with Perf Baskets: Body 150# psi Rating (10 bar)**

Particle sizes from:0.062-0.125 in (1.575-3.175 mm)

---

**Strainers with Mesh Baskets: Body 150# psi Rating (10 bar)**

Particle sizes from:0.0024-0.045 in (0.061-1.143 mm)

---

## 2" SBV05-20T

**Strainers with Perf Baskets: Body 150# psi Rating (10 bar)**

Particle sizes from:0.062-0.125 in (1.575-3.175 mm)

---

**Strainers with Mesh Baskets: Body 150# psi Rating (10 bar)**

Particle sizes from:0.0024-0.045 in (0.061-1.143 mm)

---

Select a specific particle size in the pricing pages from either the Perf or Mesh groups.