

Model PRH-04

High Pressure Regulator (Reducing Valve)

NPT threaded ports

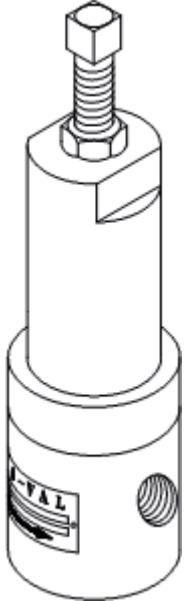

- Spring and piston operated
- 1/2"-2" NPT threaded
- Inlet pressures to 5000 PSI (340 Bar)
- Outlet pressures to 4500 PSI (306 Bar) (multiple spring ranges; see table below)
- Max operating temperatures -40 to 400 °F (-40 to 204 °C)

Features

- **Pressure-containing parts** made from solid bar stock materials — unlike castings which have wall thickness variations.
- **Body and trim:** Standard material is type 303 or 316 stainless steel. Special alloys (e.g. Hastelloy, Monel, titanium, and Alloy 20) also available.
- **Teflon PTFE V packing seals:** High-pressure, low-friction, self-expanding design permits operation with small differences between inlet and outlet pressures as low as 50-75 PSI (approx), as long as the packing nut is not overtightened and piston surfaces are kept clean.
- **Spring chamber and adjusting spring:** These parts are non-wetted, are not in contact with the fluid or gas, and are normally offered in carbon steel, painted for minimal exterior corrosion-resistant protection. When these parts are submerged or located in a corrosive atmosphere, they can be upgraded to a stainless steel or other corrosion-resistant materials at an additional cost. The spring chamber is not offered in aluminum or plastic.
- **Standard porting:** Right-angle porting, NPT threads (side inlet, bottom outlet). Valve works in any orientation, upright as illustrated, horizontal, etc. See also flanged model **PRH-04-FLG**.

- **Optional porting:** Side outlet (parallel port), or in-line porting can be supplied at additional cost when requested.
- **Other options:** Reduced trim for low-flow applications, locking cap, inlet or outlet pressure gauge ports, Teflon or Viton seats for inlet pressures below 3000 psig (20 barg), 1/2 and 3/4" sizes only. Pressures are derated for larger sizes.

Applications

Designed for clean, filtered or strained, non-abrasive liquid service: oils, lubricants, greases, solvents, and most non-fluorinated chemicals compatible with Teflon PTFE seals. Valve is piston-operated, metal-seated without any elastomers. **Do not use for extended shutoff service** or for extremely low flows (less than 5% of maximum capacity). Values below the low limit of the spring ranges shown below can be achieved if the flow rates are substantially higher than the minimum 5% of maximum rated capacity. To be on the safe side, a relief or bypass valve should always be installed on the outlet side of the regulator (not included with valve). For outlet pressures below the ranges stated below, request model **PRH09** double piston model, that is specifically designed to handle the lower outlet pressures that the **PRH04** cannot handle. Do not use with liquids that tend to crystallize or solidify under operating conditions. Not for use on steam service as operating temperatures can easily exceed the limitations of the Teflon seals which are rated for 400 Deg F max. Consult factory for steam & gas service. The balanced piston design of this model accommodates large variations in inlet pressure. When ordered, if a set pressure is not specified, valves are set to the minimum pressure setting for the range selected. Valve can operate in any orientation: vertical, horizontal, etc. A high-pressure filter or strainer, which should be no coarser than #60 mesh, can be ordered from Stra-Val. See model **SBS-10**.

Options

- Reduced trim for low-flow applications, all sizes.
- Locking cap to enclose adjusting screw (1).
- Wetted materials (7,10) in type 316SS, Monel, titanium, and Hastelloy.
- Upgrade non-wetted spring chamber (2), spring hardware (3,5), and adjusting screw (1) to 300 series stainless steel.
- Hard-chromed piston (7) for longer life and seal (9) wear.
- 1/4" NPT inlet and outlet pressure gauge connection. Generally not recommended if accuracy is required due to turbulent location in flow stream.
- Custom materials for special applications where PTFE seals (9) may not be suitable.

Principle of Operation

This valve operates with a compression spring acting on the main valve which is used to adjust the outlet pressure with an adjusting screw. The reduced outlet pressure is very easily adjusted in the field. To increase outlet pressure, simply loosen adjusting screw lock nut (2) to increase spring compression by turning the adjusting screw (1) inward. Similarly, to get a lowering in outlet pressure requires a reduction in spring compression by turning the screw outward. A pressure gauge is required on the outlet side of the regulator somewhere in the downstream piping close to the valve, to monitor the result while making the adjustment. An optional 1/4" Npt pressure gauge connection is added, only when ordered. The valve will operate in a vertical orientation as illustrated, horizontal, or any other orientation.

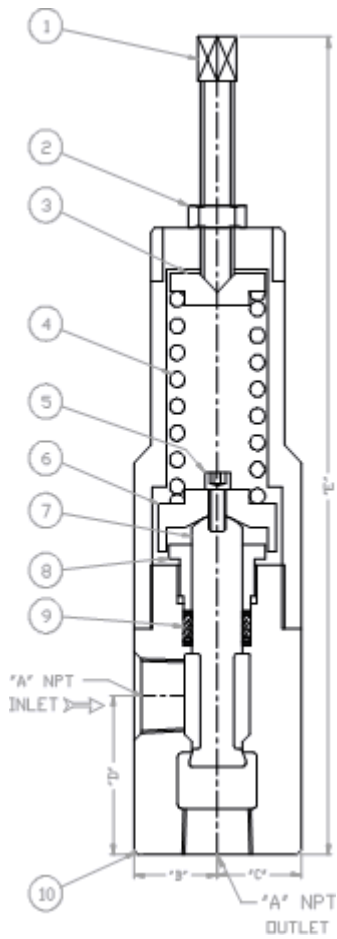

PRH-04

Material List and Specification

1.	Adjusting screw	Steel
2.	Spring chamber	Steel
3.	Spring pusher	Steel
4.	Spring	Steel
5.	Screw	Steel
6.	Spring follower	Steel
7.	Piston	303SS 316SS
8.	Packing nut	303SS
9.	Packing rings	Teflon
10.	Body	303SS 316SS

Dimensions (inch)

A	B	C	D	E
NPT				
1/2	1	1	1-7/8	11-1/2
3/4	1-1/4	1-1/4	2-1/4	12
1	1-1/2	1-1/2	2-5/8	14
1-1/4	2 3/16	1-1/2	2-1/2	14
1-1/2	2-1/2	1-1/2	3	14-1/2
2	2-1/2	1-1/2	4	16-1/2

Note: Dimensions are approximate and are subject to change without notice. Request certified dimensions before final product installation.

1/2" PRH04-05T

Max Inlet pressure 5000 psig (345 barg)

Multiple Spring Ranges from:150-4500 psig (10.3-310 barg) Select spring from pricing page

3/4" PRH04-07T

Max Inlet pressure 3000 psig (207 barg) Metal & Soft Seated Option

Multiple Spring Ranges from:150-4500 psig (10.3-310 barg) Select spring from pricing page

Max Inlet pressure 5000 psig (345 barg) - Metal Seated

Multiple Spring Ranges from:150-4500 psig (10.3-310 barg) Select spring from pricing page

1" PRH04-10T

Max Inlet pressure 3000 psig (207 barg)

Multiple Spring Ranges from:150-3000 psig (10.3-207 barg) Select spring from pricing page

Max Inlet pressure 5000 psig (345 barg)

Multiple Spring Ranges from:900-4500 psig (62.1-310 barg) Select spring from pricing page

1-1/4" PRH04-12T

Max Inlet pressure 3000 psig (207 barg)

Multiple Spring Ranges from:150-3000 psig (10.3-207 barg) Select spring from pricing page

Max Inlet pressure 3000 psig (345 barg)

Multiple Spring Ranges from:750-4500 psig (51.7-310 barg) Select spring from pricing page

1-1/2" PRH04-15T

Max Inlet pressure 3000 psig (207 barg)

Multiple Spring Ranges from:150-3000 psig (10.3-207 barg) Select spring from pricing page

Max Inlet pressure 5000 psig (345 barg)

Multiple Spring Ranges from:750-4500 psig (51.7-310 barg) Select spring from pricing page

2" PRH04-20T

Max press Rating 3000 psig (207 barg)

Multiple Spring Ranges from:150-3000 psig (10.3-207 barg) Select spring from pricing page

Max press Rating 5000 psig (345 barg)

Multiple Spring Ranges from:750-4500 psig (51.7-310 barg) Select spring from pricing page

3" PRH04-30T

Max press Rating 3000 psig (207 barg)

Multiple Spring Ranges from:150-1000 psig (10.3-69 barg) Select spring from pricing page

The spring ranges listed above are not achievable with one spring, but are compressed to show overall product capability. Select a specific spring range in the pricing pages or specify a set pressure when ordering.