

OPERATING INSTRUCTIONS

MODEL RVI-20P THD

PRESSURE RELIEF VALVE

Plastic Valve

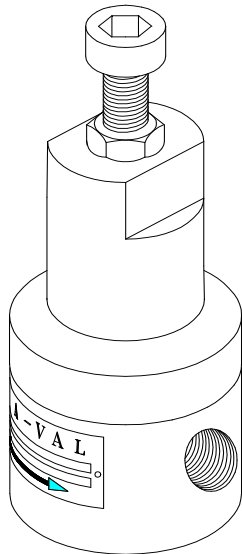

APPLICATIONS:

Valve is designed for use with corrosive liquids, where the materials selected are compatible with the fluid and will not keep the valve from functioning properly. When liquids contain debris or other solid matter, which might cause internal clogging or improper operation of the valve, a strainer or filter should be installed before the inlet of the valve..

PRINCIPLE OF OPERATION

This is a diaphragm and spring type relief valve where the spring constantly opposes the pressure acting against the diaphragm, which seals of the inlet port from the outlet port at the valve seat. The desired set pressure or relief is achieved by compressing the spring until the spring force is adequate to balance the pressure force acting against the diaphragm. When the inlet pressure exceeds the set pressure, the diaphragm will open to relieve the excess pressure. The valve is generally used on low-pressure relief service where good accuracy is required. The large diaphragm in proportion to the seat results in a large change in force unbalance with very low-pressure changes. The valve can operate in any orientation, vertical, horizontal, etc.

MAINTENANCE & REPAIR

The valve should be periodically checked for proper operation. Reducing the spring compression from its current pressure setting can easily do this. Eventually the diaphragm should open and begin to discharge

liquid. **Make sure that the discharge is properly piped to a safe area in order avoid any personal injury**

The valve is relatively maintenance free, and the only part that would require attention is the diaphragm which should be replaced immediately if found to be ruptured, or leaking. Therefore, a replacement should be kept on hand for replacement convenience.

The valve seat is the other area to examine, in case there is extreme corrosion or wear which would reduce the sealing ability against the diaphragm. If the damage is not too severe, the valve seat can be remachined and restored to produce an "as new" surface, thereby avoiding the need to purchase an entire new valve.

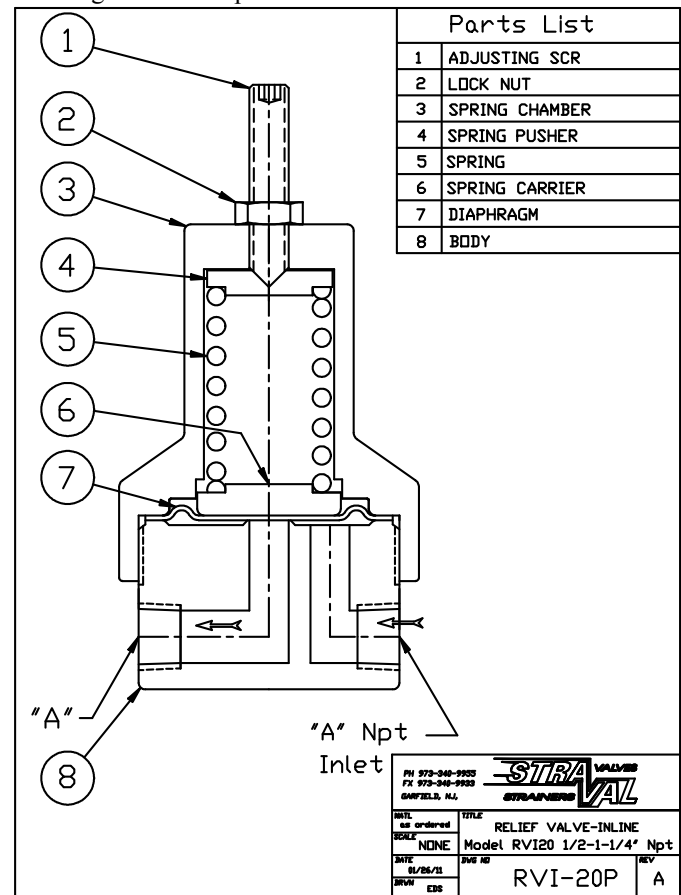

**OPERATING
INSTRUCTIONS
MODEL RVI-20P THD
PRESSURE RELIEF VALVE
Plastic Valve**

PROCEDURE FOR DISASSEMBLY

Make sure the valve is isolated and is not under pressure. Next remove the valve from the system. Back out the spring adjusting screw until there is no longer any spring compression. It may also be removed completely if desired. Unscrew the spring chamber using a strap wrench on top of the spring chamber. Now the diaphragm is exposed. Remove the diaphragm, Viton/Ptfe (Teflon). Check to see if there are any tears, cuts or severe signs of wear or abrasion, particularly, in the seat area where it contacts the valve body. Replace if in doubt. Next examine the seat, which is a raised section immediately surrounding the outlet port. Check to see that there are no obvious wear marks or any signs of erosion or debris. The seat can be re-machined or solvent/ cleaner wiped.

Don't forget to examine the adjusting spring to look for signs of corrosion or outright failure. Replace if necessary. Springs are usually always in stock at STRA-VAL and can be shipped readily.

REASSEMBLY & TEST

When all the valve parts are cleaned and inspected, the valve can be reassembled in reverse order. Also, make sure no dirt or foreign particles are embedded in the valve seat, which might cause the valve seat to stay partially open and cause unwanted leakage.

When the spring and spring hardware is assembled and the spring chamber threaded on to the body tightly. (Normally hand tight plus ¼ turn using a strap wrench) For soft materials it is best to under tighten.

Testing should be done with the valve completely piped up with the discharged piped safely away. At the proper system over pressure, turn the adjusting screw until the valve begins to open. Next reduce the system pressure to the normal operating pressure and check to see if the valve reseats properly and shuts off.

If it is not possible to change the system pressure to an overpressure condition, at which point the valve must open, then the valve must be tested and set off line using a hydrostatic testing device.