

OPERATING INSTRUCTIONS

MODEL PRS-09i FLG

PRESSURE REDUCING VALVE

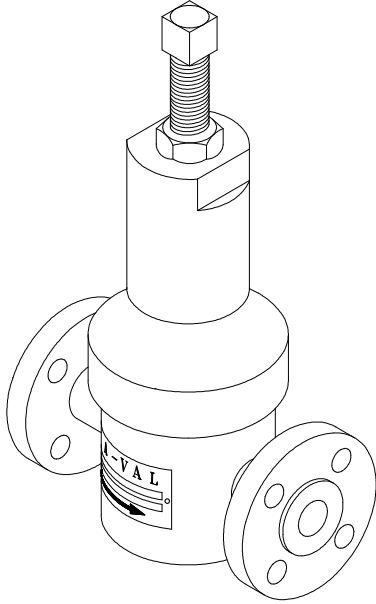

PRINCIPLE OF OPERATION

Steam or other fluid passing through the valve enters through the inlet port, through the valve seat formed by main valve and seat, and finally through the outlet port. Outlet pressure is sensed by the underside of the diaphragm through a vertical port, which connects with the outlet port. Pressure regulation is achieved when a force balance is maintained between the pressure acting on the underside of the diaphragm and the spring force, which is adjusted to hold a particular outlet pressure. If the outlet pressure is below the set point as preset by the adjusting spring, the spring force overcomes the pressure force acting on the underside of the diaphragm. This causes the main valve to open, thereby admitting higher inlet pressure fluid to raise the outlet pressure until the force balance is restored. As soon as the outlet pressure is restored, the main valve begins to close and to limit the amount of higher inlet pressure fluid passing through the valve.

Do not apply the valve on shut-off or dead ended service, as the valve is not designed for this purpose. Always install a relief valve on the outlet side of the valve.

OPERATING INSTRUCTIONS

If the valve has not been ordered preset to a specific outlet pressure, simply adjust the spring (5) compression by loosening the lock nut (2) and turn the adjusting screw (1) Clockwise to increase the spring compression. This will

increase the outlet pressure. Similarly, turning the screw counterclockwise will reduce the spring compression and correspondingly reduce the outlet pressure.

DISASSEMBLY/ASSEMBLY INSTRUCTIONS

If the regulator fails to maintain the proper outlet pressure, there could be a number of probable causes as follows: Internal clogging of foreign objects or material, sediment, rust, etc. in the valve seat area, sensing port, diaphragm cavity and valve spring cavity which houses the spring. If this condition appears frequently a strainer installed at the inlet side of the valve is recommended. If disassembly is required, make sure the valve piping is not under pressure and sufficiently cooled off for operating personnel to handle. To disassemble the valve, it is not necessary to remove the valve from the piping, although it may be more convenient to work on the valve at a bench with a vise. Unscrew the spring chamber (3) with a wrench.

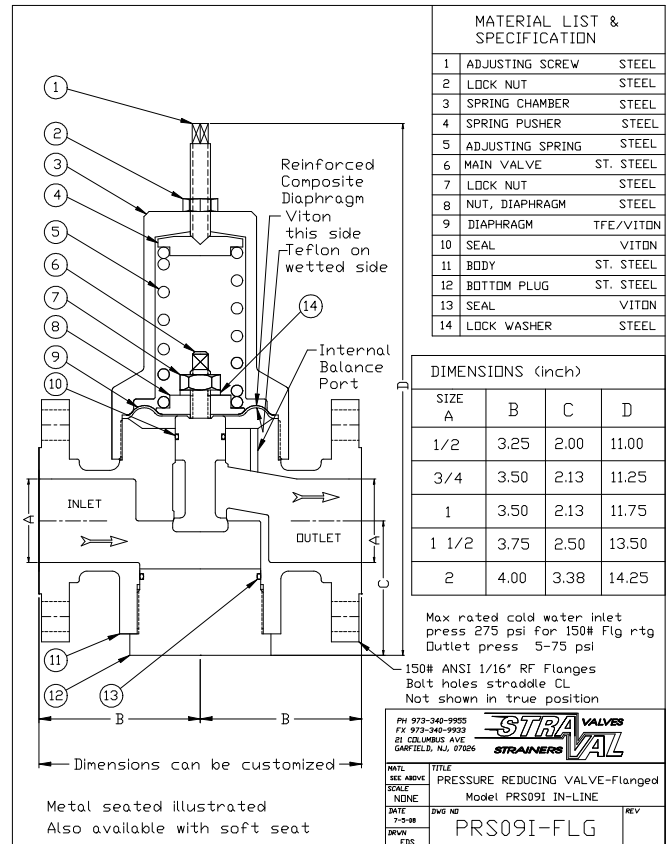

OPERATING INSTRUCTIONS MODEL PRS-09i FLG PRESSURE REDUCING VALVE

If fluid is leaking from the adjusting screw, the diaphragm is suspect. Inspect the diaphragm (9), replace if torn, abraded, or delaminated or otherwise damaged or cut. Sealing area of the diaphragm should be free from tears or cuts, otherwise external leakage will occur. Examine to see if there are signs the diaphragm pulled away from the outer clamped seating area. If so, realign diaphragm and make sure the spring chamber is tightened properly, and checked again for tightening after full temperature is reached after installation. Also, check to make sure the locknut (7) is tight which holds the diaphragm metal plates (8) to the diaphragm). A spare diaphragm should always be kept on hand to keep down time to a minimum.

Examine the main valve (6) and seat area for excessive wear particularly in the valve seat area. If excessive, replace with new parts. Otherwise, parts may be restored by remachining and re-lapping with a fine lapping compound, such as 600 or 800 grit. Replace external valve spring (5) if corroded or damaged.

Reassemble valve in the same sequence as disassembled making sure the diaphragm lock nut (6) and spring chamber (3) are tight so that no leakage can take place in these areas. Apply approximately 45 ft-lbs of torque to tighten the diaphragm lock nut (7) and approximately 500 ft-lbs to the spring chamber (3). Also examine the O-ring seal for the bottom plug to make sure it is not damaged or shows signs of deterioration. Replace if necessary.

It is often easier to assemble the spring chamber assembly upside down by dropping the spring and spring hardware into the spring chamber. Then the body (11) subassembly with the main valve (7) and diaphragm (9) can be positioned over the spring chamber (3) and threading the assembly together until hand tight. Then the final tightening with a wrench can be done with the valve right side up

After the valve is properly assembled, reset the spring adjusting screw (1) until the desired outlet pressure is achieved at the flow range the valve will be operating. Then tighten the adjusting screw lock nut (2). Note that some valves, depending on the droop characteristic, may require readjustment of the spring setting if there are wide ranges in flows. Consult factory for application assistance if a different spring or if a different valve is required.

NOTE: When the outlet pressure must be maintained at a specific value, and where excessive pressure may damage equipment, a **relief valve must be installed** on the outlet side of the regulator.