

## Model BPS-05-FLG BACK PRESSURE / BYPASS VALVE FLANGED 150#, 300#, 600# ANSI

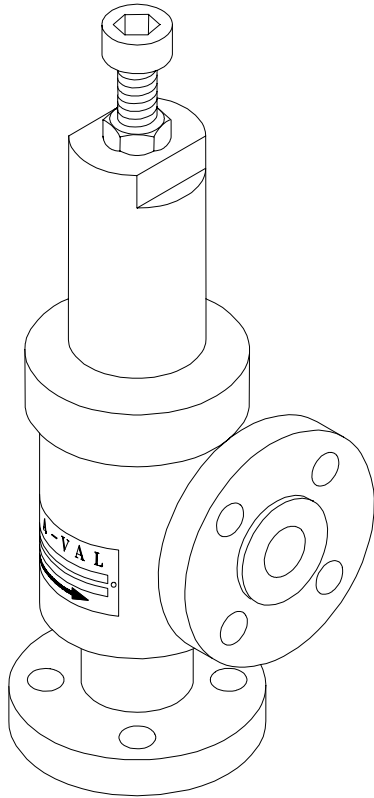

- Stainless steel, Monel, Hastelloy, titanium, or Alloy 20
- 1/2"-2" flanged (see also threaded NPT model BPS-05)
- Adjustable control pressures from 30 PSI (2 Bar) to 1400 PSI (95 Bar) at 300 °F (150 °C)

### Features

- **Body:** Standard material is stainless steel. Special alloys (e.g. Monel, titanium, Alloy 20, and Hastelloy) also available. Teflon body is also available for pressures below 150 PSI (10 Bar). Not offered in carbon steel construction except for clean lubricating oil type of services.
- **Poppet:** Also available in the same materials as the body. Teflon is available for low pressure service (<150 PSI) and where required for corrosion resistance and tighter seat shutoff.
- **Elastomeric seal:** Choice of different elastomers including Teflon expands valve usage to a wide range of applications and fluids. Choice of elastomer determines final temperature limitation.
- **Spring chamber:** Because it is non-wetted, the standard construction is carbon steel, but can be upgraded to 300 series stainless steel in aggressive environments.
- **Right-angle porting:** Standard construction is bottom inlet, side outlet. Also available with sanitary flanges for low pressures.

## Applications

This valve is used for back pressure control applications such as maintaining constant pump discharge pressures, bypassing excessive pressures from various types of process equipment, and wherever a constant pressure must be maintained in a process or piping system. Valve should only be used selectively where the materials chosen are compatible with the fluid used and will not cause corrosive buildup or crystallization in the close clearances between the piston and body bore, which could keep the poppet from opening freely. Use only clean, strained, or filtered liquids or gases so that the valve can operate without buildup of debris or solid matter which can cause the valve to malfunction. A strainer or filter with the appropriate perf or mesh and pressure rating can be purchased from Stra-Val. Apply only where the discharge piping is not subjected to a high outlet pressure, as this will affect the control pressure setting. If this pressure is steady or constant, compensating for the change in set pressure can be simply made by readjusting the spring load, or by using a different spring selection, or selecting a different valve type designed for this. Therefore, when ordering this valve please make sure both the inlet control pressure as well as the outlet pressure is stated so that this can be taken into consideration when selecting the proper valve type and model. These valves do not carry the ASME approval stamp and should not be applied where this requirement must be met. The valves however generally meet or exceed their design criteria.

## Options

Several options are available. These are: Locking cap or locking wire seal to prevent tampering with the set pressure, and a pinned anti-backout device to prevent complete removal of the spring adjusting screw. These valves are not equipped with a manual lever release. However, manual override is accomplished by first locking the spring lock nut to the adjusting screw and backing it out enough to open the poppet to release pressure, and then repositioning it to its original preset locked condition without losing the original set pressure. This procedure is recommended periodically to flush the seat and to check for proper opening of the valve piston. For material options see materials list and heading.

## Principle of Operation

This is a direct-operated poppet and spring type back pressure / bypass valve where the spring constantly opposes the pressure acting against the poppet which seals off the inlet port from the outlet port at the valve seat. The desired set pressure or control pressure is achieved by compressing the spring until the spring force is adequate to balance the pressure force acting against the poppet. When the inlet pressure exceeds the set pressure, the poppet will open to relieve the excess pressure. These valves work and even look similar to a pressure relief valve, except the relief valve will relieve the pressure at a faster rate than a back pressure valve which must control the flow rate more gradually in order to keep the inlet pressure at a more constant level. These valves can also be operated by remote pressure adjustment which can be achieved with a dome type air-loaded version. Contact factory.

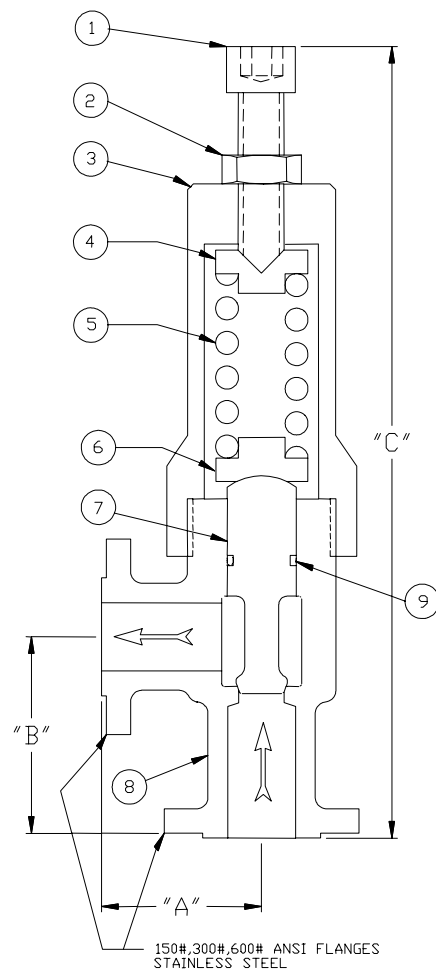

## Material List and Specification

1. Adjusting screw	Steel
2. Lock nut	Steel
3. Spring chamber	Steel
4. Spring pusher	Steel
5. Adjusting spring	Steel
6. Spring carrier	Steel
7. Poppet	Stainless steel
8. Body	Stainless steel
9. Seal	Viton, Buna, EPDM, Teflon, Kalrez

- Upgrade to all stainless steel is optional for all non-wetted parts

## Dimensions

Size	A (in)	B (in)	C (in)
1/2	2-1/2	2-1/2	8-7/8
3/4	2-3/4	2-3/4	9-3/4
1	3	2-3/4	11-1/8
1-1/4	3	3-1/2	12-1/4
1-1/2	3	4	13-1/2
2	3-1/2	4-1/2	15-1/2

Note: Dimensions are approximate and are subject to change without notice. Request certified dimensions before final product installation.