

Model BPS-05 THD BACK PRESSURE REGULATOR VALVE

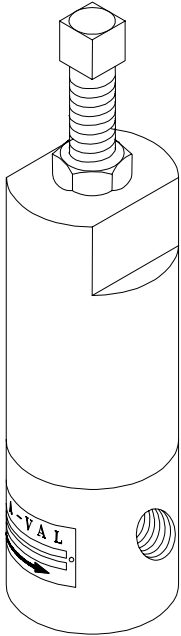

- Piston-operated pressure regulator
- 1/8"-2" NPT THD (see also flanged model BPS-05-FLG)
- Bypass valve controls pressures from 30 PSI to 3000 PSI (204 Bar) (see table below)
- Stainless steel, brass, and various exotic alloys

Pressure Regulator Features

- **Pressure-containing back pressure regulator parts** made from solid bar stock materials — unlike castings which have wall thickness variations.
- **Valve body:** Standard materials are stainless steel and brass. Special alloys (e.g. Monel, titanium, and Hastelloy) also available.
- **Piston valve/poppet:** Stainless steel is standard in bypass valve and back pressure regulator valve construction. Hardened stainless steel can be used for very high pressures.
- **Seal:** Standard bypass valve seal elastomer is Viton for stainless steel valves and Buna for brass valves. Special elastomers (EPDM, Teflon, Kalrez, and Parflour) are also available.
- **Right-angle valve porting** (bottom inlet, side outlet) is the standard piping arrangement.

Applications

This bypass valve is a corrosion-resistant valve used for very high back pressure control applications such as maintaining constant pump discharge pressures, limiting pump overpressure and bypassing excessive pressures from various types of process equipment, and wherever a constant pressure must be maintained in a process or piping system. This back pressure valve can be used for corrosive or mildly corrosive fluids, only when the proper materials are applied. When liquids or gases contain debris or other solid matter which might cause internal clogging or improper operation of the back pressure valve, a strainer with a fine wire mesh or filter should be installed before the inlet of the valve. High-pressure in-line strainer fittings or simplex basket strainers can be purchased from Stra-Val.

Principle of Operation

This is a direct-acting valve with an adjustable spring operating against a flexible elastomeric diaphragm subjected to the inlet pressure of the valve. Increasing the spring compression will increase the system or line pressure to be maintained. Reducing the spring compression will reduce the system or line pressure to be maintained. An increase in system pressure beyond the set point will cause the main valve to open and relieve the excess pressure.

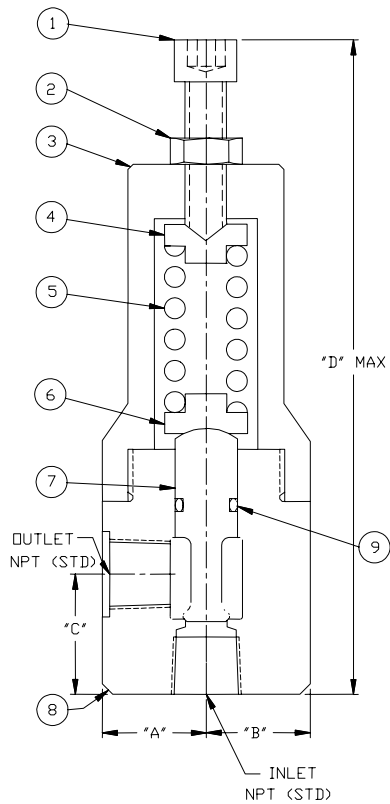

Special connections available

Material List and Specification

| | | |
|------|------------------|---------------------------------|
| 1. | Adjusting screw | Steel |
| 2. | Lock nut | Steel |
| 3. | Spring chamber | Steel |
| 4. | Spring pusher | Steel |
| 5. | Adjusting spring | Steel |
| 6. | Spring carrier | Steel |
| 7. * | Poppet | Stainless steel, brass, Teflon |
| 8. | Body | Stainless steel |
| 9. | Seal | Viton, Buna, EPDM, Teflon, etc. |

* Teflon used only for low pressures

Dimensions

| Size | A (in) | B (in) | C (in) | D (in) |
|-------|--------|--------|--------|--------|
| 1/4 | 7/8 | 7/8 | 1 | 5-3/4 |
| 3/8 | 1 | 1 | 1 | 6-1/2 |
| 1/2 | 1 | 1 | 1-3/8 | 7-3/8 |
| 3/4 | 1-1/8 | 1-1/8 | 1-5/8 | 8-1/2 |
| 1 | 1-1/2 | 1-3/16 | 2 | 10-1/4 |
| 1-1/4 | 2 | 1-1/4 | 2-1/2 | 11 |
| 1-1/2 | 2 | 1-1/2 | 2-1/2 | 12-1/4 |
| 2 | 2-3/8 | 1-1/2 | 3 | 12-1/2 |

Note: Dimensions are approximate and are subject to change without notice. Request certified dimensions before final product installation.

Copyright © Stra-Val 2005. All rights reserved.